

# EASYWINCH- MKII- SMALL BOAT ANCHOR WINCH

**Manufactured by P. & B. MARRIOTT LTD  
WHANGAMATA, NEW ZEALAND.**

## **INSTALLATION INSTRUCTIONS**

### **PARTS LIST**

- 1) Motor gear unit with rope capstan.
- 2) 4-M5 X50 countersunk stainless steel bolts, nuts & washers.
- 3) 10 amp thermal overload switch
- 4) Waterproof rocker switch – fitted but may be relocated during installation.
- 5) Installation instructions.

Unpack Unit – ensure that all parts are included- check against parts list.

Establish where you want to fit the Winch. Be sure that its location is safe and secure for crewmembers and for the operator. Only fingertip loads will be required to feed and stow anchor ropes. Do not fit the EASYWINCH in the Anchor Locker where damp and salty conditions apply.

Ensure that the mounting position is strong enough to withstand the winch pull. If necessary reinforce the deck. The required strength is equivalent to a 12mm plywood deck with some curvature. This winch could apply a short duration pull of up to 100kg force. Avoid anchor rope rubbing on any objects on its path as this only creates resistance and wear. The bow fairlead must restrain and guide the anchor rope or control may be lost. Roller types will improve the pull but skid fairleads are acceptable. Ensure the switch is within reach of the operator at all times. Gear unit, switch and motor must be protected from the weather in a well-ventilated area below the deck plate.

Position winch such that the line up from the winch to bow is fair and unobstructed. See typical installation drawing.

To dismantle winch for installation –

### **Mechanical**

- a) Remove center M6 countersunk screw only from the top of the capstan.
- b) Lift capstan off.
- c) Winch must never be operated without the capstan in place and center screw fastened, or damage may result in the gear reduction unit.
- d) Remove the four M6 countersunk screws now exposed and carefully lift plate from shaft and mounting rods.
- e) Do not bump or jar the unit as shaft is now only supported by the main bearing.
- f) Using the capstan and deck plate, position it on the boat to find the best position on the deck for operation. For best results the capstan should be vertical to the rope. If it is too far tilting forward the rope will slip off the top of the capstan, too far tilting backwards and the rope will trail against the deck plate. If such angles can not be found then a wedge must be made to position the capstan correctly. Make sure the position is flat so the deck plate is flush with the surface.
- g) Mark the position.
- h) Using the template supplied, bore one 16mm hole and four 18mm holes through the deck.
- i) Trial fit unit from under deck to deck plate. Ensure main drive shaft will not rub the deck when it rotates.

- j) Using the deck plate as a guide jig, drill the four 5mm bolt holes.
- k) Remove unit and apply sealant to the underside of deck plate and bolt the gearbox into place. The four M6 countersunk screws must remain tight.
- l) Assemble the winch to the deck plate.

## **Electrical**

- m) The switch is supplied mounted on the side of the drive. This can be clipped out and mounted in another position inside the boat to ensure the operator can reach the switch during operation. If it is chosen to keep the switch in the supplied position then a small amount of glue may be needed to ensure the switch cannot be unclipped after installation.
- n) Using the recommended cable size, wire back to the starter battery or chosen 12-volt power source.
- o) Fit thermal overload at the battery on the positive terminal. Ensure the smallest length of cable possible between the thermal overload and the battery.
- p) Make sure the thermal overload is set by depressing the button down.
- q) Note; use the shortest electrical path necessary. Longer cables will effect the performance of the winch.

## **OPERATION**

If the winch is powered from the starter battery, **ALWAYS START THE ENGINE FIRST!**

Switch the anchor winch on.

Wrap one wrap around the capstan and put slight tension on the rope.

If the rope slips too much wrap another wrap around the capstan.

Proceed to recover the rope hand over hand in a smooth action.

Switch the winch off and recover the chain by hand (the anchor winch will be damaged if the chain comes in contact with the capstan).

The thermal overload will trip if the winch is overloaded, reset if needed.

Be aware, this winch is not fitted with an anti-reversing clutch.

In usual operation the winch should not be stalled.

Never use the winch as a bollard. Damage may result.

### **WARNING –**

In spite of the EASYWINCH's small size the pull loads are high enough to be dangerous. Do not allow any irresponsible use and be sure the operator is fully aware of the safe use of the product.

## MAINTENANCE

### Cleaning-

Hose capstan with fresh water. Clean with soap and warm water if required.

### Lubrication-

Every 6 months grease moving parts.

This includes the stainless steel shaft bearings, at the deck plate and gearbox, the “layshaft”, the small shaft that protrudes slightly out of the gearbox.

The capstan should be removed every 6 months and the splined shaft greased to prevent seizure to the capstan.

If the drive is to be used a lot then regular maintenance should be made to the gear train. Remove the gearbox end plates to access the gear train.

Grease gears liberally with “HP marine grease”. Do not introduce any foreign particles and certainly DO NOT RUN GEARBOX WITHOUT THE ENDPLATES. This could result in one less finger!

### Specification

EASYWINCH motor- Reduction Unit- Shafting - Capstan & Deck plate- Case- No load output speed Continuos rope pull Maximum pull Electrical motor control Motor stall protection Weight Maximum deck thickness	90watts output continuos, 200watts maximum output. – 12 volt DC Helical gear train, 36:1 ratio Stainless steel Aluminum Aluminum commercial anodized black 90rpm 35kg 100kg sealed rocker switch, Thermal overload 3.5kg 40mm
--	--

### Electrical cable required

For cable lengths up to 1mtr-

2sq.mm

For cable lengths up to 5mtr to 7mtr-

6sq.mm- 8sq.mm

Wiring should be direct to the battery rather through existing ‘house’ wiring, as this will seldom be heavy enough.

### Capstan rotation

User choice-

Set to anti-clockwise, positive to red, clockwise, positive to black.

If the direction is to be clockwise then ensure that the switch and thermal overload all operate on the positive side of the winch. I.e. reverse the wiring at the motor, not the battery.

Special note

As with all deck machinery that is subject to marine conditions-

**“IF YOU WANT TO TAKE IT APART LATER YOU HAD BETTER GREASE IT”**

For best results keep the above deck parts greased and the below deck parts dry.

Warranty does not apply when motor and gearbox are fitted in damp salty conditions.

**DO NOT FIT THE EASYWINCH IN THE ANCHOR LOCKER.**

Fitting suggestions are enclosed

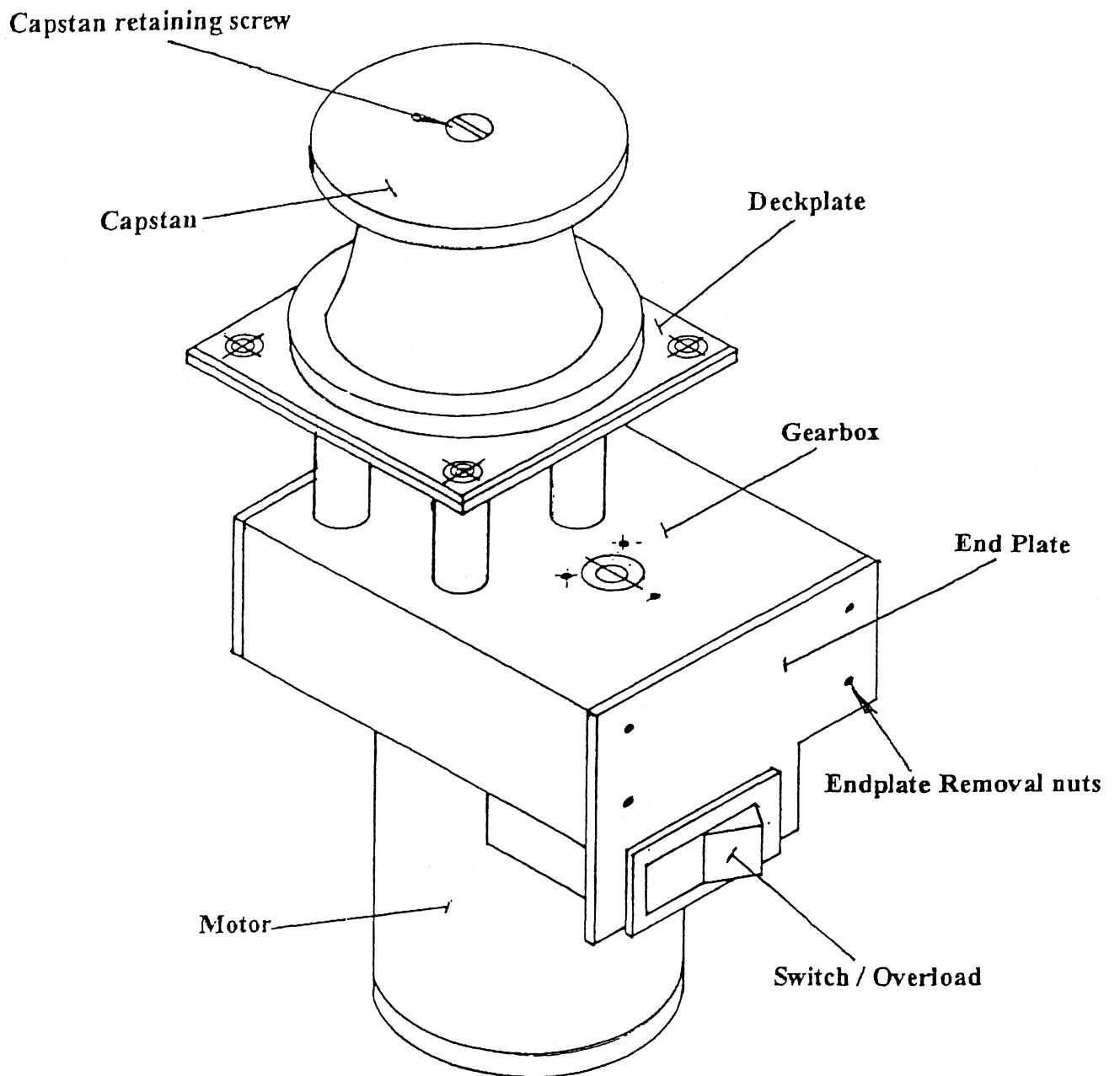

**EASYWINCH**  
12 Volt D.C. - 10 Amp. (Nominal)

Manufactured By -  
P. & B. Marriott Ltd  
Whangamata  
New Zealand

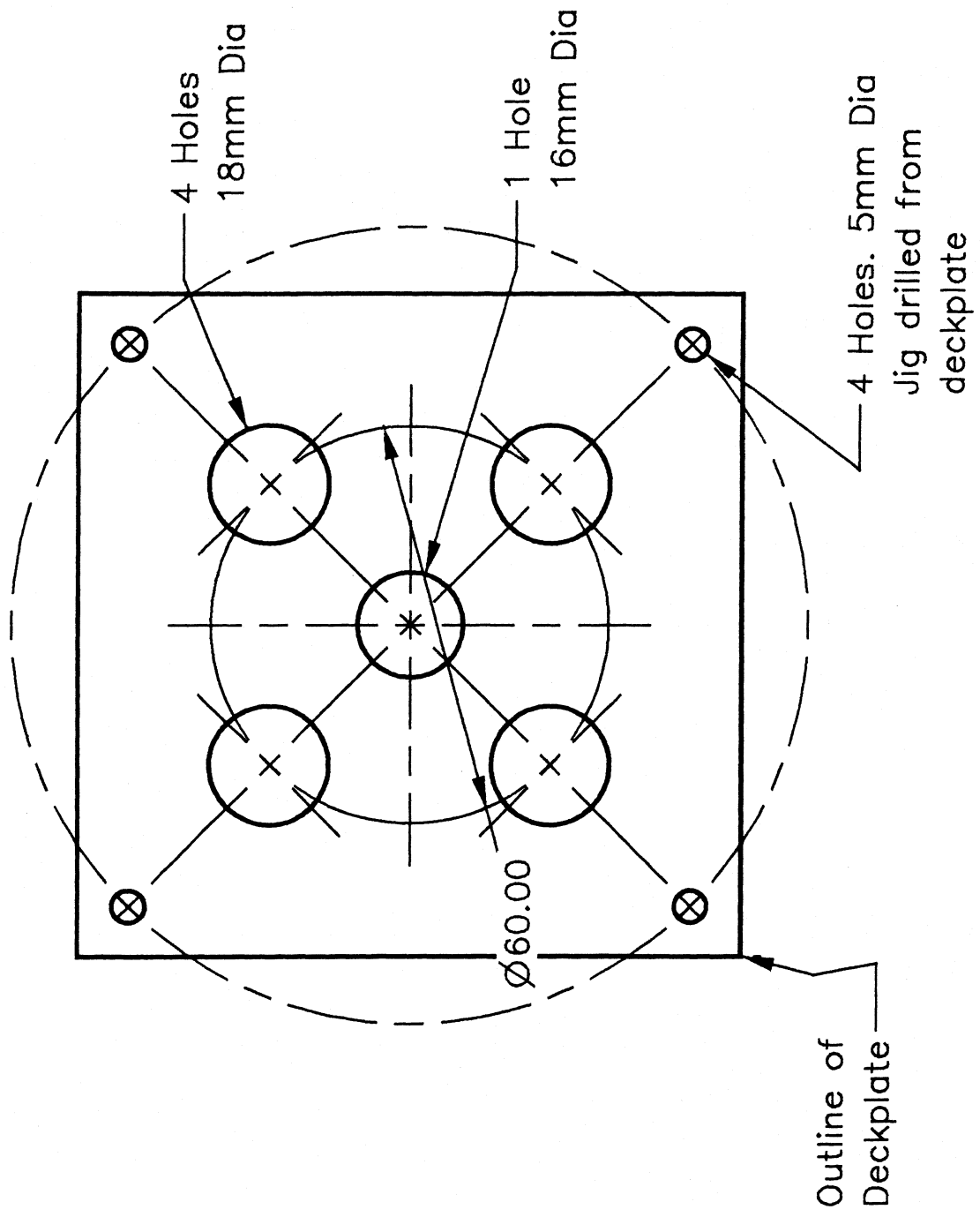

**TEMPLATE FOR HOLES IN DECKPLATE TO MOUNT**  
**"EASYWINCH" SCALE - FULL SIZE**

MANUFACTURED BY  
 P & B MARRIOTT LTD  
 NEW ZEALAND

# ADVANCE WINCH 300W AND 600W MARINE CAPSTAN ANCHOR WINCH

Manufactured by P&B MARRIOTT LTD  
New Zealand

## INSTALLATIONS INSTRUCTIONS

### PARTS LISTS

1. Motor gear unit with stainless steel capstan
2. 4x M8 threaded rods, M8 nuts and washers (304 s/s)
3. Instructions incl. Deck template and wiring instructions

Unpack unit- ensure that all parts are included- check against the list.

Establish where you want to fit the winch. Be sure that its location is safe and secure for crewmembers and for the operator. This winch is designed for marine environment. It maybe fitted in the anchor locker for anchor retrieval or mounted exterior to the boat as a davit, Cray pot/crab pot winch.

Ensure that the mounting position is strong enough to withstand the maximum winch pull .*See specifications table.* In most installations deck reinforcement will be necessary especially for the more powerful ADVANCE WINCH 600W. Avoid anchor rope rubbing on any objects on its path as this only creates resistance and wear. The bow fairlead must restrain and guide the anchor rope or control may be lost. Roller fairleads will improve the pull but skid fairleads are acceptable. Ensure the switch is within reach of the operator at all times.

Position winch such that the line up from the winch is fair and unobstructed. See typical installation drawing.

### Mechanical Installation

- a. Unscrew the 4 M8 stainless steel nuts from the threaded rods. Also remove spring washes and plain washes from the winch.
- b. Choose position for the winch to be mounted. The winch may be mounted with the motors inside the anchor locker. For best result, the capstan should be vertical to the rope. If it is tilting too far forward the rope will slip off the top of the capstan. Too far tilting backwards and the rope will trail against the deck plate. If such angles cannot be found on the boat deck, then a wedge must be made to position the capstan correctly. *See typical fitting.* Make sure the mounting position is flat so the deck plate is flush with the surface.
- c. Follow the deck template instruction and create appropriate holes.
- d. Install unit by liberally applying silicon sealant to the underside of the deck plate and bolt the winch into place. (Note: Make sure that the threaded rods are fully screwed into the deck plate).

### Electrical Installation

- a. Mount operational switch so that it will always be within reach of the operator.
- b. Follow wiring diagram. Use the shortest length of electrical cable possible, as this will increase the winch's performance.

- c. Use correct cable sizes as shown in the cable selection.
- d. If winch electrical terminals are to be fitted in damp or wet conditions then coat the electrical connections in a water repellant spray, silicon sealant, soft seal or epoxy.
- e. The winch can be set to run either clockwise or anti-clockwise. Change polarity at the winch terminals if anti-clockwise direction is desired. Be advised, slightly better performance is given when winch is connected to run clockwise. Normal clockwise operation is positive to red.

*Note, Rotation is taken from looking at the top of the winch*

### CABLE SELECTION

Cable length	ADVANCE WINCH 300W	ADVANCE WINCH 600W
Below 16'(5mtr)	10mm <sup>2</sup>	15mm <sup>2</sup>
16'(5mtr)-33'(10mtr)	15mm <sup>2</sup>	25mm <sup>2</sup>
Above 33'(10mtrs)	25mm <sup>2</sup>	35mm <sup>2</sup>

### ELECTRICAL DIAGRAM/TYPICAL FITTING

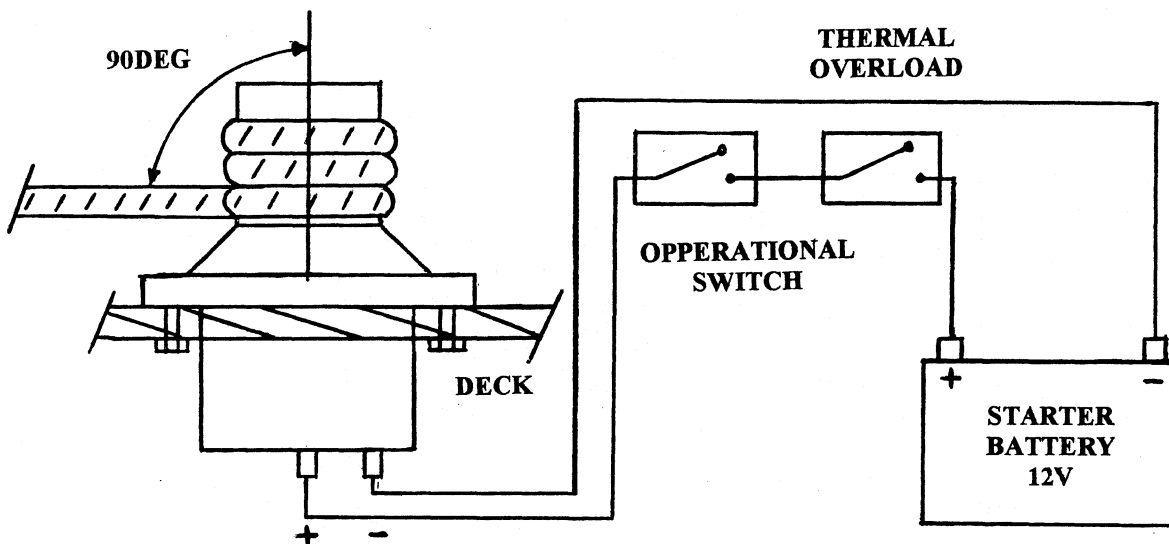

### OPERATION

If the winch is powered from the starter battery, **ALWAYS START THE ENGINE FIRST.**

Switch the anchor winch on.

Wrap one wrap around the capstan and put slight tension on the rope.

If the rope slips too much, wrap another wrap around the capstan.

Proceed to recover the rope hand over hand in a smooth action.

Switch the winch off and recover the chain by hand (the anchor winch will be damaged if the chain comes in contact with the capstan).

Be aware this winch is not fitted with an anti reversing clutch.

In usual operation the winch should not be stalled.

Never use the winch as a ballad, damage may result.

**WARNING-** In spite of the ADVANCE WINCHES small size the pull loads are high enough to be dangerous. Do not allow any irresponsible use and be sure the operator is aware of the safe use of the product.

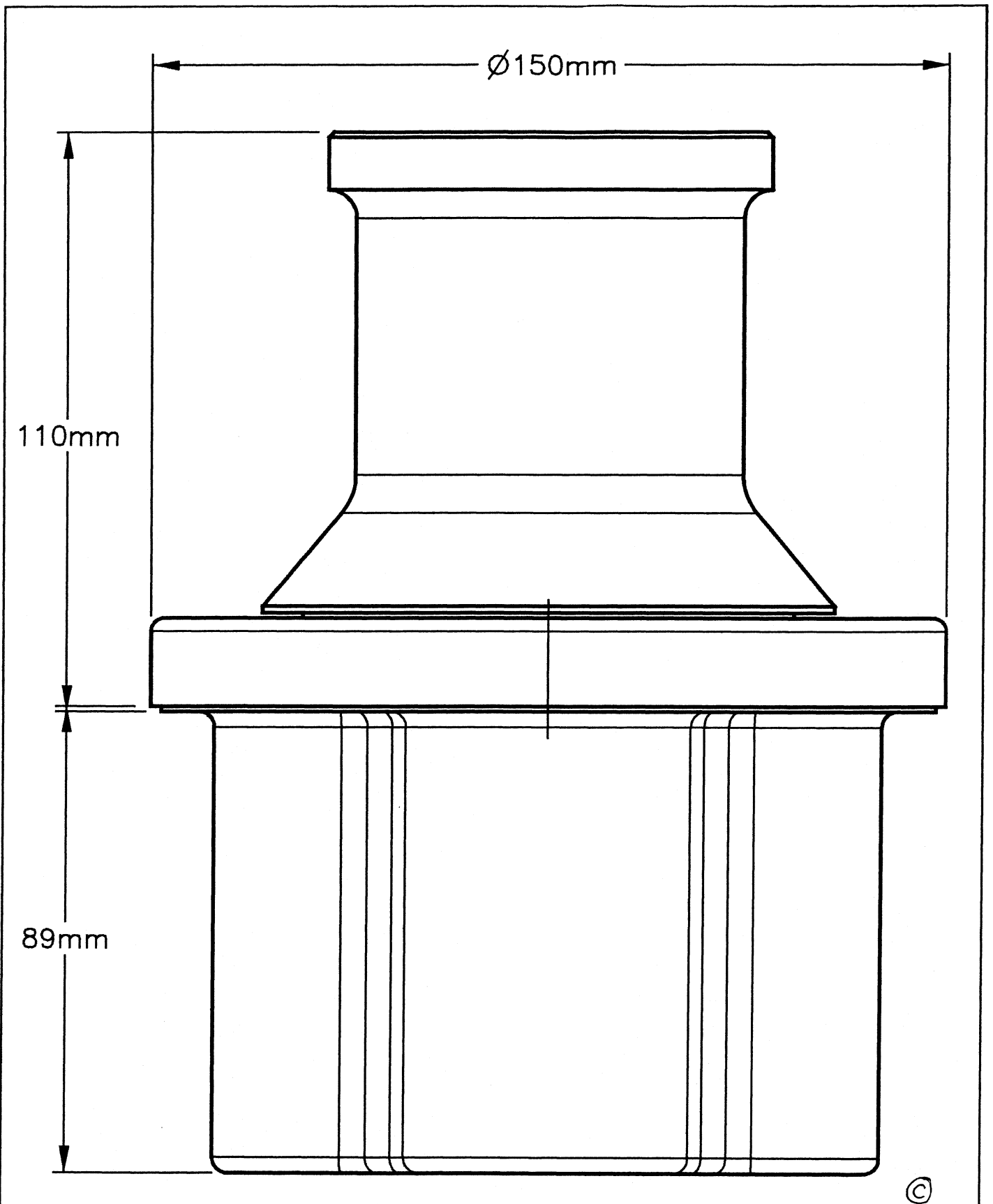

BASIC DIMENSIONS OF  
ADVANCE 300W AND ADVANCE  
600W.  
(TRUE SCALE DIMENSIONS).

P & B MARRIOTT LTD  
NEW ZEALAND

MINIMUM SIZE OF 8MM DIA  
MAX 10MM.  
PITCH CIRCLE IS 120MM  
DIAMETER.

FOR BEST RESULTS A 65MM HOLESAW  
SHOULD BE USED

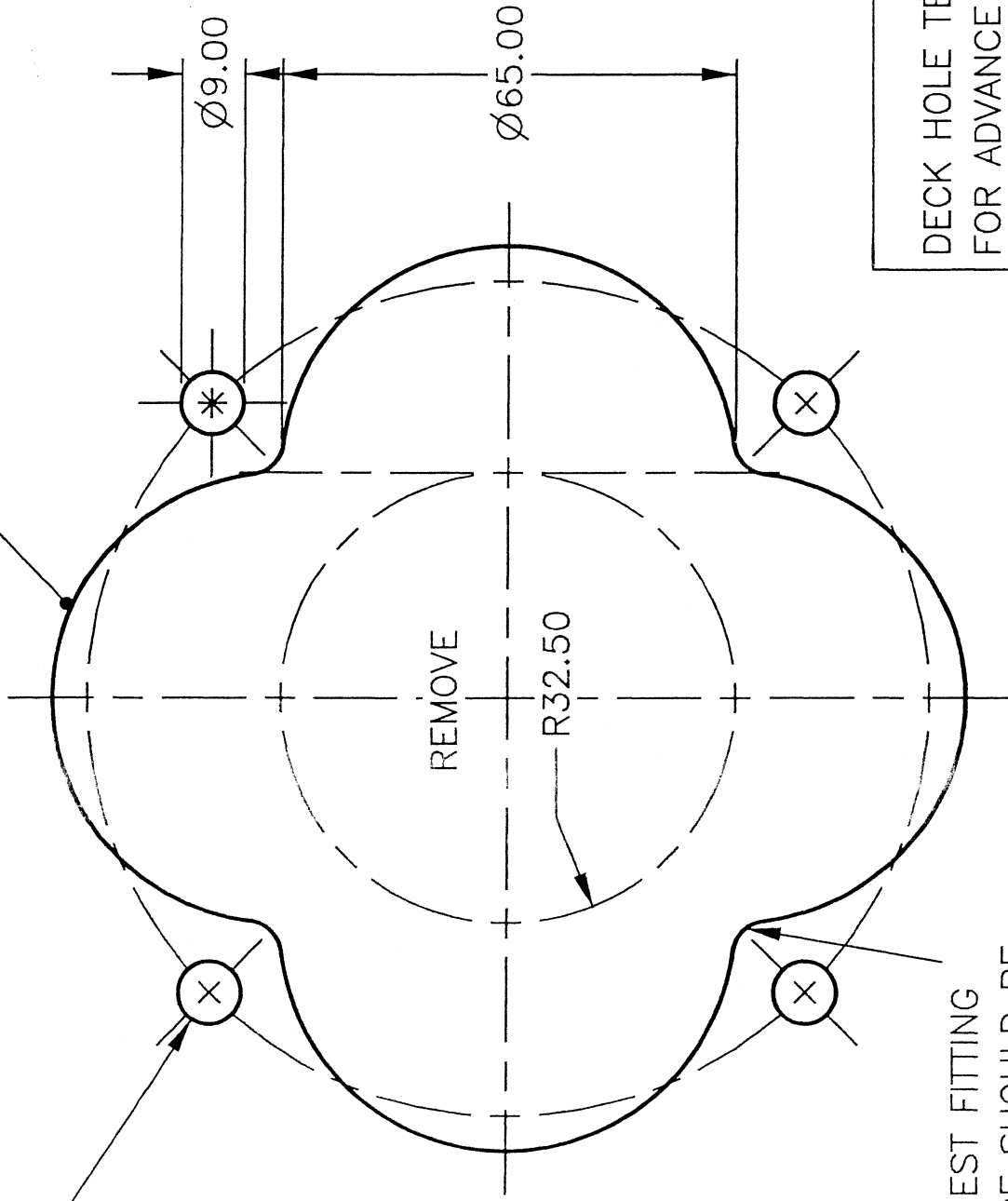

FOR EASIEST FITTING  
THIS EDGE SHOULD BE  
ROUNDED TO APPROX  
10MM DIAMETER

DECK HOLE TEMPLATE  
FOR ADVANCE WINCH 300W  
& 600W  
P & B MARRIOTT LTD  
NEW ZEALAND

©